



VACUUM PACKING MACHINE SU-520P L 230/50-60/1

Tabletop model. 20m³/h. 555 mm.



P/N 1141112



SALES DESCRIPTION

555 mm sealing bar.
20 m³/h Busch vacuum pump.
Vacuum controlled by sensor.

- ✓ Powered by Busch.
- ✓ Vacuum controlled by sensor.
- ✓ Vacuum PLUS.
- ✓ LCD colour screen: all information at a glance.
- ✓ Backlit touch keyboard.
- ✓ Programmable: 25-programme memory. Blocking option.
- ✓ "Pause" button.
- ✓ Phased vacuum programme.
- ✓ Detection of the evaporation of liquids.
- ✓ Double seal.
- ✓ Cordless sealing bar.
- ✓ Progressive decompression.
- ✓ Vac-Norm ready with Automatic decompression.
- ✓ Stainless steel body and chamber. Long-shaped, deep-drawn chamber.
- ✓ Damped transparent lid of high durability polycarbonate.
- ✓ Dry-oil programme for drying the pump.
- ✓ Working hours counter for oil changes.
- ✓ Safety system with protection against vacuum failure.

INCLUDES

- ✓ Filling plate
- ✓ Printer connection
- ✓ Bluetooth connectivity

OPTIONAL

- Printer
- Vacuum packing pouches
- Vac-Norm external vacuum kit, containers and accessories
- Bag cutting kit
- Support for liquids
- Additional filling plates

ACCESSORIES

- Bag cutting kits
- Filling plates
- Liquid insert plates
- Vac-norm external vacuum kits
- Vac-norm containers
- Smooth bags for vacuum packing
- Trolley for vacuum packing machines
- Thermal labels for CG2 / RB printer
- RB Desktop printer for SU vacuum packing machines
- Thermal transfer labels for RB printer

SPECIFICATIONS

Pump capacity: 20 m³/h
 Pump capacity (60 Hz): 20 m³/h
 Bar length: 555 mm
 Total loading: 750 W
 Vacuum pressure (maximum): 2 mbar
 Electrical supply: 230 V / 50-60 Hz / 1 ~ (5.5 A)

Internal dimensions

- ✓ Width: 568 mm
- ✓ Depth: 431 mm
- ✓ Height: 215 mm

External dimensions (WxDxH)

- ✓ Depth: 552 mm
- ✓ Height: 513 mm (230V) / [v:dim_ext_alto_2] (120V)
- ✓ Width: 634 mm
- ✓ Depth: 552 mm
- ✓ Height: 513 mm

Net weight: 70.4 Kg

Noise level (1m.): 75 dB(A)
 Background noise: 32 dB(A)

Crated dimensions

786 x 612 x 685 mm
 Gross weight: 79 Kg

FOOD PRESERVATION AND SOUS-VIDE
VACUUM PACKING MACHINES - "SENSOR ULTRA" LINE

product sheet
updated 05/10/2022



SAMMIC, S.L.
Bassa de, 1 - 20720 Azzovita
www.sammic.com



VACUUM PACKING MACHINE SU-520P L 230/50-60/1

Tabletop model. 20m³/h. 555 mm.



P/N 1141112

FOOD PRESERVATION AND SOUS-VIDE
VACUUM PACKING MACHINES - "SENSOR ULTRA" LINE

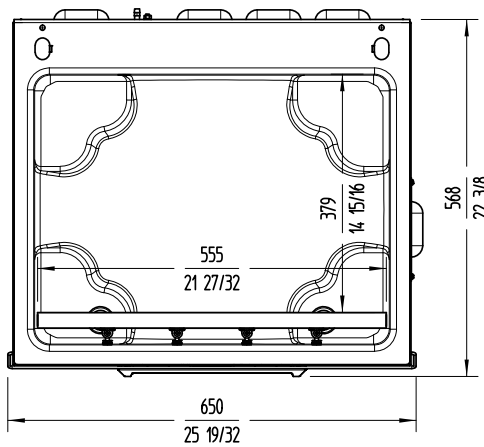
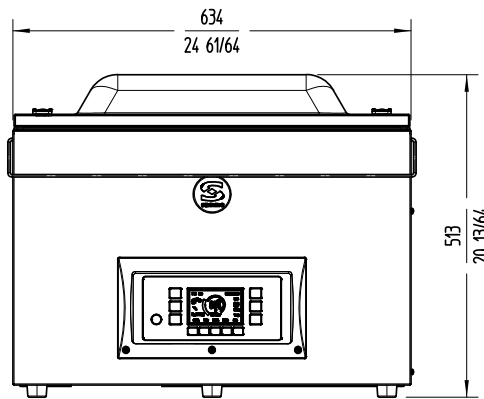
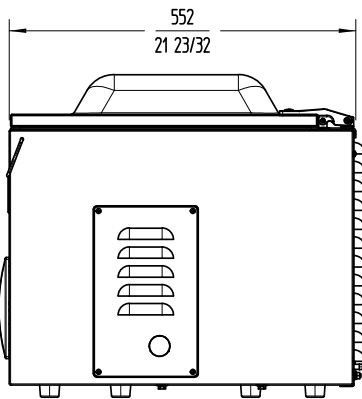

www.sammic.co.uk

Food Service Equipment Manufacturer

Unit 2, Trevanth Road

Troon Industrial Park

LE4 9LS - Leicester

uksales@sammic.com

Tel.: +44 0116 246 1900



Project	Date
Item	Qty
Approved	

product sheet
updated 05/10/2022